

SHIMANO CAPREO Front Chainwheel FC-F700

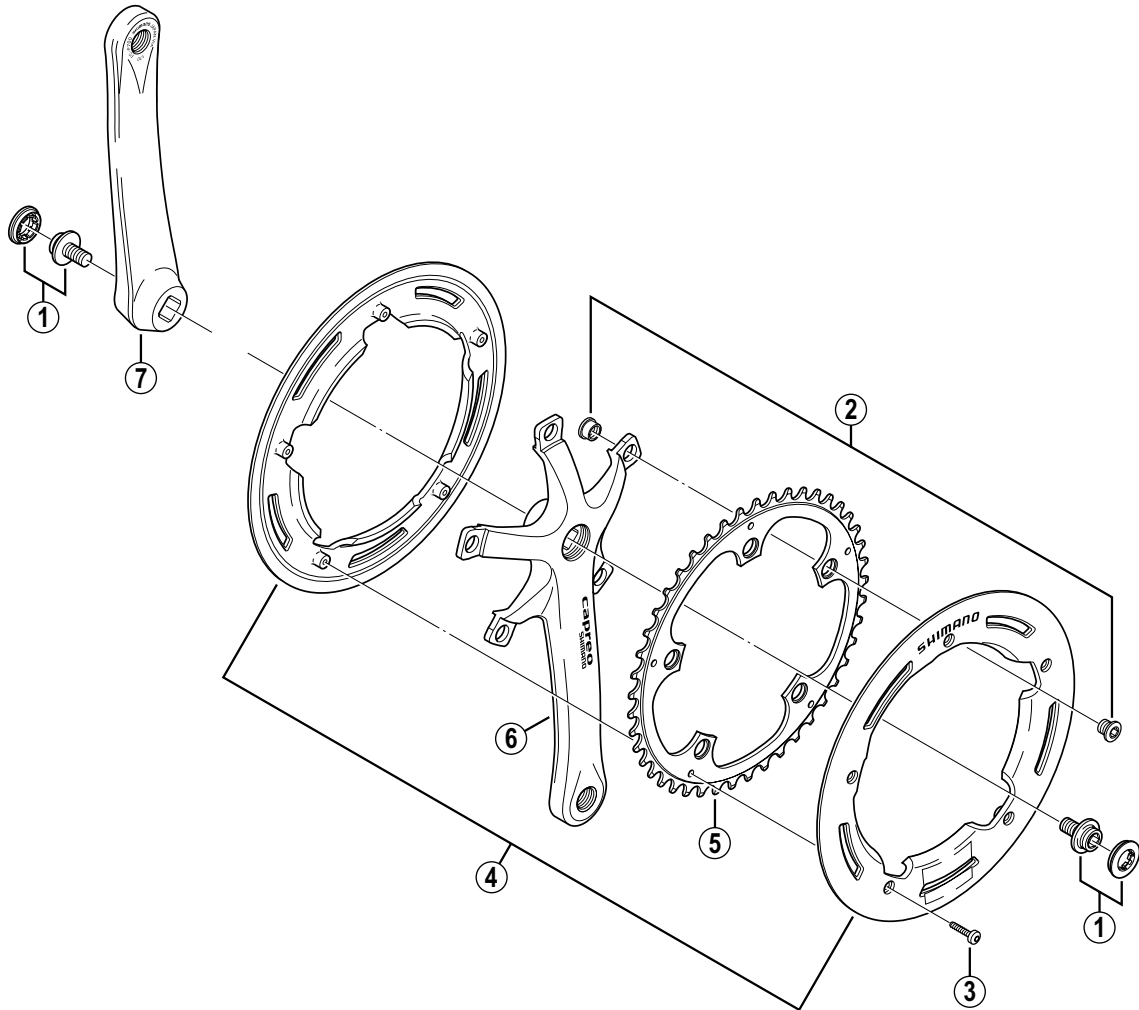

• Bolt circle diameter: 130 mm

FC-4400

ITEM NO.	SHIMANO CODE NO.	DESCRIPTION	INTERCHANGEABILITY
1	Y-16M 90100	Crank Arm Fixing Bolt & Cap	A
2	Y-1F1 98010	Gear Fixing Bolt (M8 x 7) & Nut (5 sets)	
3	Y-1F1 98020	Chain Guard Fixing Bolt (5 pcs.)	
4	Y-1F1 98030	Chain Guard A & B	
5	Y-1F1 45000	Chainring 45T	
6	Y-1DM03010	Right Hand Crank Arm 165 mm	B
	Y-1DM02010	Right Hand Crank Arm 170 mm	B
7	Y-1DM03110	Left Hand Crank Arm 165 mm	B
	Y-1DM02110	Left Hand Crank Arm 170 mm	B

A : Same parts.

B : Parts are usable, but differ in materials, appearance, finish, size, etc.

Absence of mark indicates non-interchangeability.

0208-2182

Specifications are subject to change without notice.